

Solar Mounting Solutions

Composition/Asphalt Shingle Roofs



Quick Mount PV[®]
RESPECT THE ROOF



QBlock® Composition Mounts

The Classic Composition Mount and the E-Mount series are designed for fast, simple installation onto existing composition/asphalt shingle roofs. Both mounts use Quick Mount PV's QBlock Elevated Water Seal technology for a long, watertight life on the roof. Both series are also available with multiple attachment options: lag bolt, hanger bolt and extended hanger bolt.

Use the Classic Composition Mount when your project demands the highest quality mount on the market. The heavier, 12" x 12" flashing provides added protection for extreme climate zones.

The E-Mount, with a smaller, lighter flashing, is ideal for price-sensitive jobs in less extreme, milder climate zones.

Features

- QBlock Elevated Water Seal technology
- Works with all leading racks
- Fits in standard 5- to 5.625-inch shingle course
- One-bolt installation; no shingle cutting
- Approved by leading roof manufacturers; won't void roof warranty



12" x 12" aluminum flashing, .05" thick

Classic Composition Mount Series

Certified for strength and waterproofing by the ICC-ES (ICC-ESR-2835). Available with three attachment options: standard 6" hanger bolt, extended 6.5" hanger bolt, or lag bolt.

Available finishes: aluminum mill (A); bronze anodized (B); clear anodized (C)

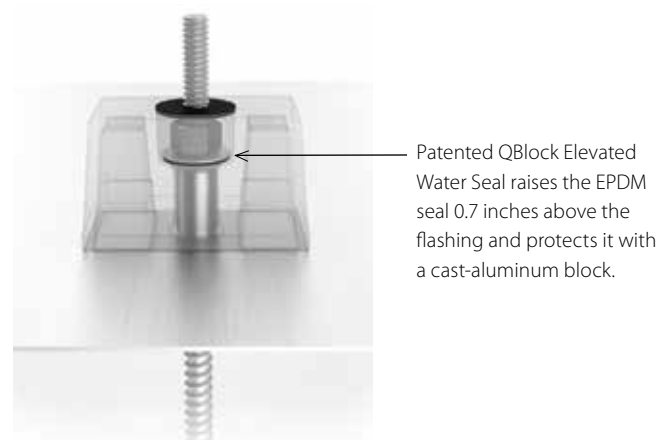

Classic Comp Mount with hanger bolt

- Meets or exceeds roofing industry best practices; 100% IBC compliant
- 2554 lbs. average pullout (Douglas fir); 2203 lbs. average shear
- 18-8 stainless steel hardware included
- 20-year warranty



12" x 9" aluminum flashing, .04" thick

The E-Mount Series

The E-Mount series is available with three attachment options: standard 6" hanger bolt, extended 6.5" hanger bolt, or lag bolt.

Available finishes: aluminum mill (A); bronze anodized (B)

QBase® Composition Mount

The QBase Composition Mount is designed for cost-effective solar installation during new construction or roof replacement, and features QBase technology for superior strength and waterproofing. The base and post mounting system integrates seamlessly with the construction workflow.

Features

- Spun aluminum cone flashing with no welds or seams
- Works with all leading racks
- Attaches to roof structure with either 2 or 4 fasteners
- 2 fasteners and all hardware included; exposed hardware is 18-8 stainless steel
- Meets or exceeds roofing industry best practices; 100% IBC compliant
- 20-year warranty



QBase Composition Mount

The strongest base-and-post mount available. 20-year limited warranty. Available finishes: aluminum mill (A), bronze anodized (B), clear anodized (C)

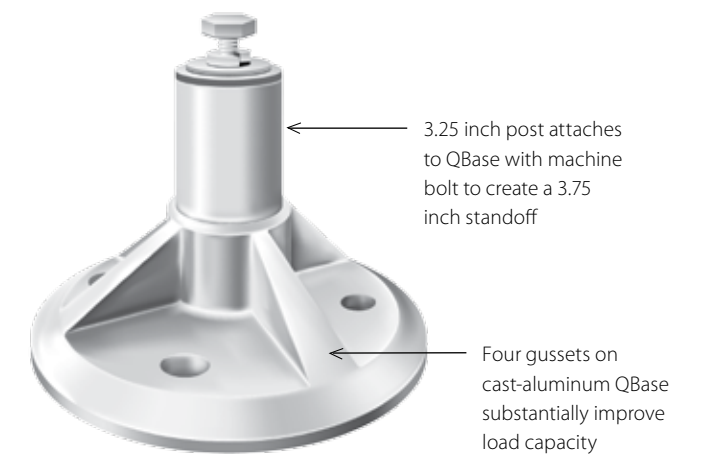

EASY INSTALLATION

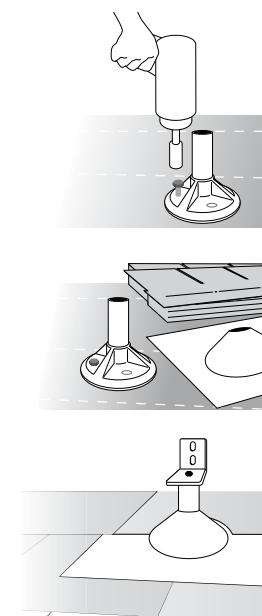

1. Mount the QBase and post after the sheeting is nailed down.

2. Leave the flashing for the roofers to install with the roof.

3. Install the array after the roofing is finished.

Conduit Composition Mounts

Protecting Conduit from Water and Heat

Safeguarding the conduit that encases a PV system's electrical wiring is just as important as protecting the roof and solar array. Quick Mount PV's products protect conduit above the roof and allow leak-proof penetrations through the roof.



Classic Conduit Mount

The Classic Conduit Mount lifts conduit off the roof to protect wiring from overheating. This mount features Elevated Water Seal technology to seal the roof penetration, and uses aluminum and stainless steel parts to secure the conduit for the life of the system.



Conduit Penetration Flashing

The Conduit Penetration Flashing provides a quick, easy way to install conduit through the roof while protecting against water intrusion with the seamless, all-aluminum spun cone flashing. The innovative EPDM post collar can be customized by the installer to fit a 1/2", 3/4" or 1" diameter conduit.



(925) 478-8269 ■ sales@quickmountpv.com
2700 Mitchell Dr., Bldg 2 ■ Walnut Creek, CA 94598
www.quickmountpv.com

